



# MUD PUMPS AND CLEANING SYSTEMS



## ABOUT AMERICAN AUGERS MUD PUMPS AND CLEANING SYSTEMS

From 200-1000 gallons per minute (GPM), American Augers' Mud Cleaning Systems are designed to compliment mid-size and large horizontal directional drills. The cleaning capacity is based on true drilling fluid being processed through the system and measured at the first cut.

American Augers is committed to manufacturing equipment that helps to preserve the sanctity of the global environment, and has done so by reducing noise and/or emissions outputs, and emphasizing the fact that our trenchless technology equipment requires little or no open cutting, which has minimal impacts on natural surfaces, features, or habitats.

## MUD PUMPS



**P-750**  
pg. 11

## CLEANING SYSTEMS



**M-200D**  
pg. 1



**M-300D**  
pg. 3



**M-500PD**  
pg. 5



**MCD-1000**  
pg. 7

# M-200D

200 GPM OF TRUE CLEANING CAPACITY

# MUD CLEANING SYSTEM



### Cleaning System

**Derrick® FLC-503™ Linear Motion Shaker (1):** 3 panel with 34.5 ft² non-blank screen area

**Shaker Screens Included:** (1) API 60 Derrick PMD+ (pyramid plus)  
(1) API 50 Derrick PMD+ (pyramid plus)  
(1) API 140 Derrick PMD+ (pyramid plus)

**1st Cut Shaker Cleaning Capacity:** up to 200 U.S. gal. (760 L)/min

**Desilting Cones:** (5) 5 in (127 mm) desilter hydrocyclones

**Desilting Capacity:** up to 600 U.S. gal. (2,271 L)/min

### Tanks

**Total Tank Capacity:** 3,000 U.S. gal (11,356 L)

**Screen Tank:** 1,700 U.S. gal (6,435 L)

**Clean Fluid/Mixing Tank:** 1,300 U.S. gal (4,921 L)

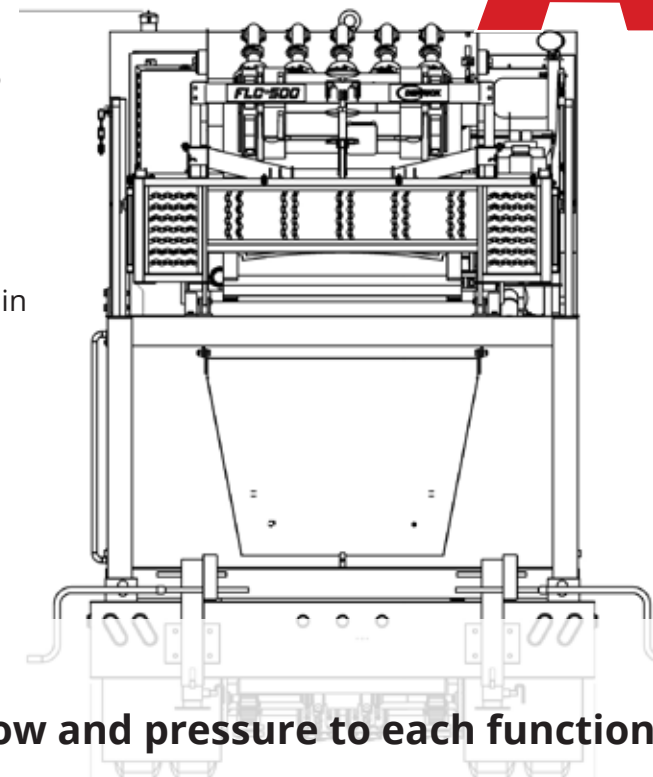

- Packaged to fit on low space jobsites
- 3 dedicated centrifugal pumps to ensure flow and pressure to each function
- Tank agitation prevents solids settling in each tank compartment
- Trailer or skid mounted units gives flexibility
- Compatible with any drill brand

### Power Train

**Generator Set:** Gen-Tech 90kW is standard

**Fuel Capacity:** 55 U.S. gal (208 L)

### Operating Controls

Pendant for offload (supercharge) start/stop

Pit pump pendant/control start/stop

### Mud Pumps

**Centrifugal Pumps:** 250 series with mechanical seal and 25 HP motors

**Cone Supply & Agitation:** 3 in x 4 in with 10.5 in Impeller

**Mud Mix & Agitation:** 3 in x 4 in with 10.5 in Impeller

**Offload & Agitation:** 3 in x 4 in with 9 in Impeller

**Bentonite Mixer:** Polyethylene dry bentonite mix hopper



### Dimensions/Weights

<b>Length:</b>	20 ft (6.1 m) without trailer	26.2 ft (7.98 m) with trailer
<b>Height:</b>	10 ft (3.05 m) without trailer	13 ft (3.96 m) with trailer
<b>Width:</b>	8 ft (2.44 m) with or without trailer	
<b>Total Weight:</b>	21,000 lbs without trailer	27,600 lbs with trailer

# M-300D

300 GPM OF TRUE CLEANING CAPACITY

# MUD CLEANING SYSTEM



## Cleaning System

**Derrick® FLC-504™ Linear Motion Shaker (1):** 4 panel with 46 ft<sup>2</sup> non-blank screen area

**Shaker Screens Included:** (1) API 50 Derrick PMD+ (pyramid plus)  
 (2) API 60 Derrick PMD+ (pyramid plus)  
 (1) API 140 Derrick PMD+ (pyramid plus)

**1st Cut Shaker Cleaning Capacity:** up to 300 U.S. gal (1,136 L)/min

**Desilting Cones:** (5) 5 in (127 mm) desilter hydrocyclones

**Desilting Capacity:** up to 600 U.S. gal (2,271 L)/min

## Tanks

**Total Tank Capacity:** 3,100 U.S. gal (11,735 L)

**Screen Tank:** 1,800 U.S. gal (6,814 L)

**Clean Fluid/Mixing Tank:** 1,300 U.S. gal (4,921 L)

- Packaged to fit on low space jobsites
- 3 dedicated centrifugal pumps to ensure flow and pressure to each function
- Tank agitation prevents solids settling in each tank compartment
- Trailer or skid mounted units gives flexibility
- Compatible with any drill brand



**Power Train**  
**Generator Set:** Gen-Tech 90kW is standard  
**Fuel Capacity:** 55 U.S. gal (208 L)

**Operating Controls**  
 Pendant for offload (supercharge) start/stop  
 Pit pump pendant/control start/stop

**Mud Pumps**  
**Centrifugal Pumps:** 250 series with mechanical seal and 25 HP motors  
**Cone Supply & Agitation:** 3 in x 4 in with 10.5 in Impeller  
**Mud Mix & Agitation:** 3 in x 4 in with 10.5 in Impeller  
**Offload & Agitation:** 3 in x 4 in with 9 in Impeller  
**Bentonite Mixer:** Polyethylene dry bentonite mix hopper



## Dimensions/Weights

<b>Length:</b>	22.6 ft (6.9 m) without trailer	27.3 (8.3 m) with trailer
<b>Height:</b>	10 ft (3.05 m) without trailer	13 ft. (3.96 m) with trailer
<b>Width:</b>	8ft (2.44 m) with or without trailer	
<b>Total Weight:</b>	22,000 lbs without trailer	28,600 lbs with trailer

# M-500PD

500 GPM OF TRUE CLEANING CAPACITY

# MUD CLEANING SYSTEM



MUD CLEANING SYSTEM

CLEANING CAPACITY

ON-BOARD PUMP

DERRICK SHAKERS

## Cleaning System

**Derrick® FLC-503™ Linear Motion Shaker (2):** 3 panel with 34.5 ft<sup>2</sup> non-blank screen area each

**Shaker Screens Included:** (3) API 50 Derrick PMD+ (pyramid plus)  
(3) API 170 Derrick PMD+ (pyramid plus)

**1st Cut Shaker Cleaning Capacity:** up to 500 U.S. gal. (1,893 L)/min

**Desilting Cones:** (10) 5 in (127 mm) desilter hydrocyclones

**Desilting Capacity:** up to 900 U.S. gal (3,407 L)/min

## Tanks

**Total Tank Capacity:** 6,600 U.S. gal (24,983 L)

**Screen Tank:** 3,000 U.S. gal (11,356 L)

**Clean Fluid/Mixing Tank:** 3,600 U.S. gal (13,627 L)

## Dimensions/Weights

**Length:** 53 ft (16.2 m)

**Height:** 13.1 ft (4 m)

**Width:** 8.2 ft (2.5m)

**Total Weight:** 75,000 lbs

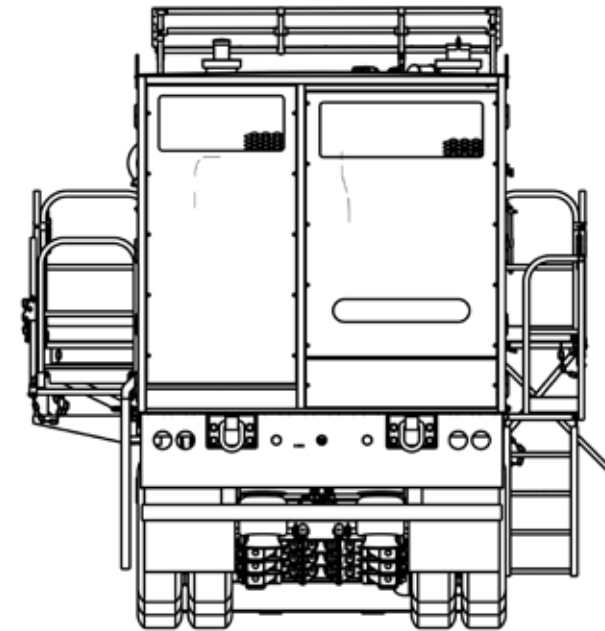

- Self-contained fluid system puts the pump and cleaning on one platform
- 3 dedicated centrifugal pumps to ensure flow and pressure to each function
- Mechanical tank agitation reduces buildup of solids in the tanks
- Convenient control placement from both ends of the unit
- Compatible with any drill brand

## Power Train

**Generator Set:** Stateline 180kW is standard

**Fuel Capacity:** 300 U.S. gal (1,135 L)

## Operating Controls

Pendant for offload (supercharge) start/stop

Pit pump pendant/control start/stop

## Mud Pumps

**Centrifugal Pumps:** 250 series with mechanical seal

**Cone Supply 40HP:**

6 in x 5 in with 10.5 in Impeller

**Mud Mix & Agitation 40HP:**

6 in x 5 in with 10.5 in Impeller

**Supercharge 25 HP:**

6 in x 5 in with 9.5 in Impeller

**Bentonite Mixer:** Polyethylene dry bentonite mix hopper



# MCD-1000

1000 GPM OF TRUE  
CLEANING CAPACITY

# MUD CLEANING SYSTEM



## Cleaning System

**Derrick® FLC-503™ Linear Motion Shaker (4):** 3 panel with 34.5 ft² non-blank screen area each

**Shaker Screens Included:** (6) API 50 Derrick PMD+ (pyramid plus)  
(3) API 120 Derrick PMD+ (pyramid plus)  
(3) API 200 Derrick PMD+ (pyramid plus)

**1st Cut Shaker Cleaning Capacity:** up to 1,000 U.S. gal. (3,785 L)/min

**Desilting Cones:** (16) 5 in. (127 mm) desilter hydrocyclones

**Desilting Capacity:** up to 1,280 U.S. gal. (4,845 L)/min

## Tanks

**Total Tank Capacity:** 9,300 U.S. gal. (35,204 L)

**Screen Tank:** 3,800 U.S. gal. (14,385 L)

**Clean Fluid/Mixing Tank:** 2,800 U.S. gal. (10,600 L)

**Intermediate Tank:** 2,700 U.S. gal. (10,221 L)

## Dimensions/Weights

**Length:** 53 ft. (16.2 m)

**Height:** 13.6 ft (4.11 m)

**Width:** 8.2 ft (2.5m)

**Total Weight:** 75,000 lbs.

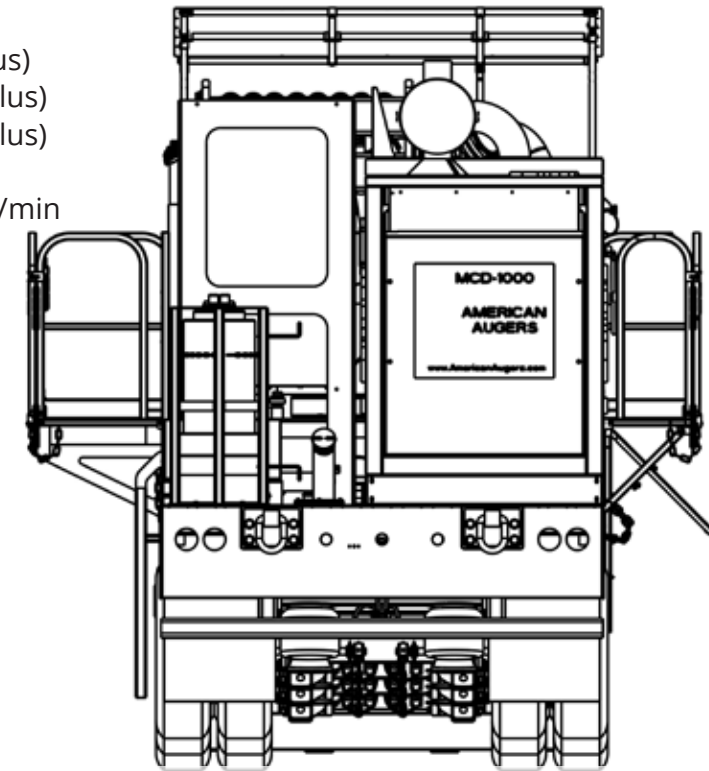

## Power Train

**Generator Set:** Stateline 265kW is standard.

**Fuel Capacity:** 300 U.S. gal (1,135 L)

## Operating Controls

Pendant for offload (supercharge) start/stop

Pit pump pendant/control start/stop

## Mud Pumps

**Centrifugal Pumps:** 250 series with mechanical seal

**(2) Cone Supply 50HP:** 6 in x 5 in with 11 in Impeller

**Mud Mix & Agitation 50HP:** 6 in x 5 in with 11 in Impeller

**Supercharge 30HP:** 6 in x 5 in with 9.5 in Impeller

**Bentonite Mixer:** Polyethylene dry bentonite mix hopper

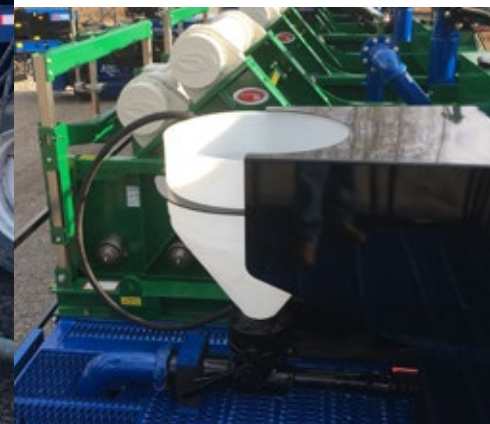

- Mechanical tank agitation reduces buildup of solids in the tanks
- 3-tank system paired with 4 Derrick FLC 503 linear motion shakers
- Clean down to 1/4% sand content of heavy backreamed fluid
- Convenient control placement from both ends of the unit
- Compatible with any drill brand

**FEATURES DRIVEN BY  
CUSTOMER FEEDBACK**

# MUD CLEANING SYSTEMS

# PERFORMANCE SPECIFICATIONS

## M-200D

### Power Train

**Generator Set:** Gen-Tech 90kW is standard.

**Fuel Capacity:** 55 U.S. gal. (208 L)

### Operating Controls

Pendant for offload (supercharge) start/stop

Pit pump pendant/control start/stop

### Mud Pumps

**Centrifugal Pumps:** 250 series with mechanical seal and 25 HP motors

**Cone Supply & Agitation:** 3 in x 4 in with 10.5 in Impeller

**Mud Mix & Agitation:** 3 in x 4 in with 10.5 in Impeller

**Offload & Agitation:** 3 in x 4 in with 9 in Impeller

**Bentonite Mixer:** Polyethylene dry bentonite mix hopper

### Cleaning System

**Derrick® FLC-503™ Linear Motion Shaker (1):** 3 panel with 34.5 ft² non-blank screen area

**Shaker Screens Included:** (1) API 60 Derrick PMD+ (pyramid plus)  
(1) API 50 Derrick PMD+ (pyramid plus)  
(1) API 140 Derrick PMD+ (pyramid plus)

**1st Cut Shaker Cleaning Capacity:** up to 200 U.S. gal. (760 L)/min

**Desilting Cones:** (5) 5 in. (127 mm) desilter hydrocyclones

**Desilting Capacity:** up to 600 U.S. gal. (2,271 L)/min

### Tanks

**Total Tank Capacity:** 3,000 U.S. gal. (11,356 L)

**Screen Tank:** 1,700 U.S. gal. (6,435 L)

**Clean Fluid/Mixing Tank:** 1,300 U.S. gal. (4,921 L)

## M-300D

### Power Train

**Generator Set:** Gen-Tech 90kW is standard.

**Fuel Capacity:** 55 U.S. gal. (208 L)

### Operating Controls

Pendant for offload (supercharge) start/stop

Pit pump pendant/control start/stop

### Mud Pumps

**Centrifugal Pumps:** 250 series with mechanical seal and 25 HP motors

**Cone Supply & Agitation:** 3 in x 4 in with 10.5 in Impeller

**Mud Mix & Agitation:** 3 in x 4 in with 10.5 in Impeller

**Offload & Agitation:** 3 in x 4 in with 9 in Impeller

**Bentonite Mixer:** Polyethylene dry bentonite mix hopper

### Cleaning System

**Derrick® FLC-504™ Linear Motion Shaker (1):** 4 panel with 46 ft² non-blank screen area

**Shaker Screens Included:** (1) API 50 Derrick PMD+ (pyramid plus)  
(2) API 60 Derrick PMD+ (pyramid plus)  
(1) API 140 Derrick PMD+ (pyramid plus)

**1st Cut Shaker Cleaning Capacity:** up to 300 U.S. gal. (1,136 L)/min

**Desilting Cones:** (5) 5 in. (127 mm) desilter hydrocyclones

**Desilting Capacity:** up to 600 U.S. gal. (2,271 L)/min

### Tanks

**Total Tank Capacity:** 3,100 U.S. gal. (11,735 L)

**Screen Tank:** 1,800 U.S. gal. (6,814 L)

**Clean Fluid/Mixing Tank:** 1,300 U.S. gal. (4,921 L)

## M-500PD

### Power Train

**Generator Set:** Stateline 180kW is standard.

**Fuel Capacity:** 300 U.S. gal. (1,135 L)

### Operating Controls

Pendant for offload (supercharge) start/stop

Pit pump pendant/control start/stop

### Mud Pumps

**Centrifugal Pumps:** 250 series with mechanical seal

**Cone Supply 40HP:** 6 in x 5 in with 10.5 in Impeller

**Mud Mix & Agitation 40HP:** 6 in x 5 in with 10.5 in Impeller

**Supercharge 25HP:** 6 in x 5 in with 9.5 in Impeller

**Bentonite Mixer:** Polyethylene dry bentonite mix hopper

### Cleaning System

**Derrick® FLC-503™ Linear Motion Shaker (2):** 3 panel with 34.5 ft² non-blank screen area each

**Shaker Screens Included:** (3) API 50 Derrick PMD+ (pyramid plus)  
(3) API 170 Derrick PMD+ (pyramid plus)

**1st Cut Shaker Cleaning Capacity:** up to 500 U.S. gal. (1,893 L)/min

**Desilting Cones:** (10) 5 in. (127 mm) desilter hydrocyclones

**Desilting Capacity:** up to 900 U.S. gal. (3,407 L)/min

### Tanks

**Total Tank Capacity:** 6,600 U.S. gal. (24,983 L)

**Screen Tank:** 3,000 U.S. gal. (11,356 L)

**Clean Fluid/Mixing Tank:** 3,600 U.S. gal. (13,627 L)

## MCD-1000

### Power Train

**Generator Set:** Stateline 265kW is standard.

**Fuel Capacity:** 300 U.S. gal. (1,135 L)

### Operating Controls

Pendant for offload (supercharge) start/stop

Pit pump pendant/control start/stop

### Mud Pumps

**Centrifugal Pumps:** 250 series with mechanical seal

**(2) Cone Supply 50HP:** 6 in x 5 in with 11 in Impeller

**Mud Mix & Agitation 50HP:** 6 in x 5 in with 11 in Impeller

**Supercharge 30HP:** 6 in x 5 in with 9.5 in Impeller

**Bentonite Mixer:** Polyethylene dry bentonite mix hopper

### Cleaning System

**Derrick® FLC-503™ Linear Motion Shaker (4):** 3 panel with 34.5 ft² non-blank screen area each

**Shaker Screens Included:** (6) API 50 Derrick PMD+ (pyramid plus)  
(3) API 120 Derrick PMD+ (pyramid plus)  
(3) API 200 Derrick PMD+ (pyramid plus)

**1st Cut Shaker Cleaning Capacity:** up to 1,000 U.S. gal. (3,785 L)/min

**Desilting Cones:** (16) 5 in. (127 mm) desilter hydrocyclones

**Desilting Capacity:** up to 1,280 U.S. gal. (4,845 L)/min

### Tanks

**Total Tank Capacity:** 9,300 U.S. gal. (35,204 L)

**Screen Tank:** 3,800 U.S. gal. (14,385 L)

**Clean Fluid/Mixing Tank:** 2,800 U.S. gal. (10,600 L)

**Intermediate Tank:** 2,700 U.S. gal. (10,221 L)

# TRANSPORTATION INFORMATION

## M-200D

**Transport Type:** Pintle hitch trailer

### Dimensions/Weights

**Length:** 20 ft. (6.1 m) without trailer  
26.2 ft (7.98 m) with trailer

**Height:** 10 ft (3.05 m) without trailer  
13 ft. (3.96 m) with trailer

**Width:** 8ft. (2.44 m) with or without trailer

**Total Weight:** 21,000 lbs. without trailer  
27,600 lbs. with trailer

## M-300D

**Transport Type:** Pintle hitch trailer

### Dimensions/Weights

**Length:** 22.6 ft. (6.9 m) without trailer  
27.3 (8.3 m) with trailer

**Height:** 10 ft (3.05 m) without trailer  
13 ft. (3.96 m) with trailer

**Width:** 8ft. (2.44 m) with or without trailer

**Total Weight:** 22,000 lbs. without trailer  
28,600 lbs. with trailer

## M-500PD

**Transport Type:** Skid mount

### Dimensions/Weights

**Length:** 53 ft (16.2 m)

**Height:** 13.1 ft (4 m)

**Width:** 8.2 ft (2.5m)

**Total Weight:** 75,000 lbs

## MCD-1000

**Transport Type:** Rock-over design on tri-axle suspension

### Dimensions/Weights

**Length:** 53 ft (16.2 m)

**Height:** 13.6 ft (4.11 m)

**Width:** 8.2 ft (2.5m)

**Total Weight:** 75,000 lbs



### Operating Controls

- Mud Pump Throttle
- Mud Pump Start/Stop
- Clutch Actuator
- Horn
- Pendant for offload (supercharge) start/stop
- Digital Mud Flow Meter



### Mud Pump

- Pump Design:** Quintiplex piston and liner
- Bore x Stroke:** 5.5 in x 7.87 in (139.7 mm x 200 mm)
- Maximum Flow:** 750 U.S. gal (2,839 L)/min
- Maximum Pressure:** 1500 PSI (103 Bar)



### Dimensions/Weights

- Length:** 25.6 ft (7.8 m)
- Height:** 10.3 ft (3.12 m)
- Width:** 8.2 ft (2.5 m)
- Total Weight:** 47,800 lbs



### Power Train

- Engine:** MTU Tier 4
- Fuel Capacity:** 300 U.S. gal (1,135 L)
- Rating:** 617 HP (460 kW)
- Transmission:** Eaton RTLO-22918B, 10-speed
- Battery:** (2) Deka 908DMF 12 V, 1450 CCA



- Maximum power Downhole
- Assists large HDD to boost production
- Keep the bore flushed clean of cuttings
- Compact skid design provides a small footprint for your jobsite
- Compatible with any drill brand





**AMERICAN  
AUGERS®**

FR42-1  
-B Rev. A  
561  
005

[www.AmericanAugers.com](http://www.AmericanAugers.com)

[sales@americanaugers.com](mailto:sales@americanaugers.com)

+1 (419) 869-7107 or 1-800-324-4930