

**KEEPING THE
WORLD
RUNNING
SMOOTHLY.**

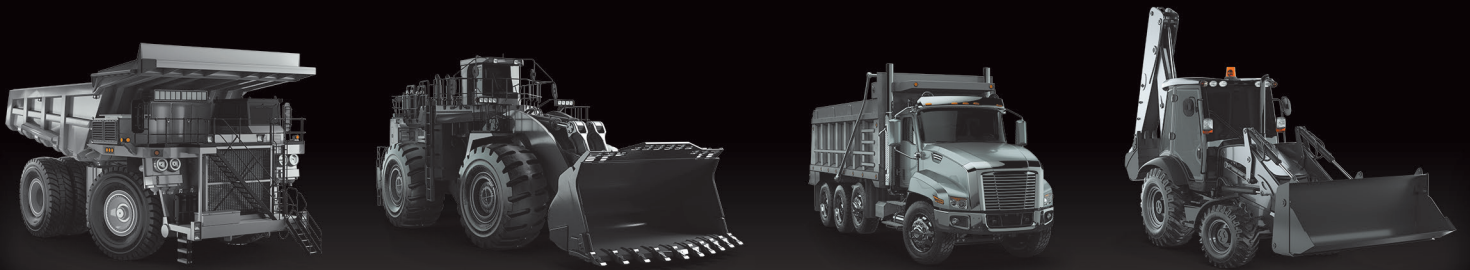

HEAVY-DUTY PRODUCTS
CONSTRUCTION

**Graders. Loaders. Dozers. Dump trucks. Cranes.
We offer the most innovative lubricants for every
piece of heavy equipment on any project—from
the moment you break ground until the final
inspection is complete.**



First, you move the dirt. Then, you move concrete, glass and steel. And through it all, you must remain moved by your own tenacity and grit—while protecting your equipment from the grit of the earth that threatens to stop progress in its continuous tracks.



HYDRAULICS

POWERDRIVE® SYNTHETIC ALL-SEASON TO-4 FLUID

Premium, synthetic multifunctional fluid for transmissions, final drives and hydraulic systems where Caterpillar TO-4 requirements are specified

POWERDRIVE FLUID 10W

High-performance multifunctional fluid for transmissions, final drives and hydraulic systems where Caterpillar TO-4 requirements are specified

T5X® OFF-ROAD MOBILE HYDRAULIC FLUID

High-performance fluid for Caterpillar hydraulic systems and other off-highway mobile equipment, plus in hydrostatic transmissions of some off-road equipment

Dedicated hydraulic systems only:

SYNCON® AW HYDRAULIC FLUID

Premium-quality, synthetic anti-wear hydraulic fluid for industrial and mobile equipment operating at extreme temperatures

POWERFLOW™ HE HYDRAULIC OIL

High-viscosity-index, anti-wear hydraulic oil for mobile equipment operating in cold climates and under wide temperature variations

ULTRA POWERFLOW HE

Ultra-high-efficiency, high-viscosity-index, anti-wear hydraulic oil for use in cold climates or under wide temperature variations. Recommended for use in construction equipment manufactured by Komatsu and others

MEGAFLOW® AW HVI 32

High-viscosity-index, anti-wear hydraulic oil for industrial and mobile equipment operating in cold climates or in locations with wide temperature variations

DIFFERENTIALS AND AXLES

MP GEAR LUBE

Multipurpose, API GL-5/MT-1, gear lubricant for truck axles with hypoid gear sets and some heavy-duty manual transmissions

POWERDRIVE FLUID 50

High-performance multifunctional fluid for differentials, final drives and heavy-duty manual transmissions where Caterpillar TO-4 requirements are specified

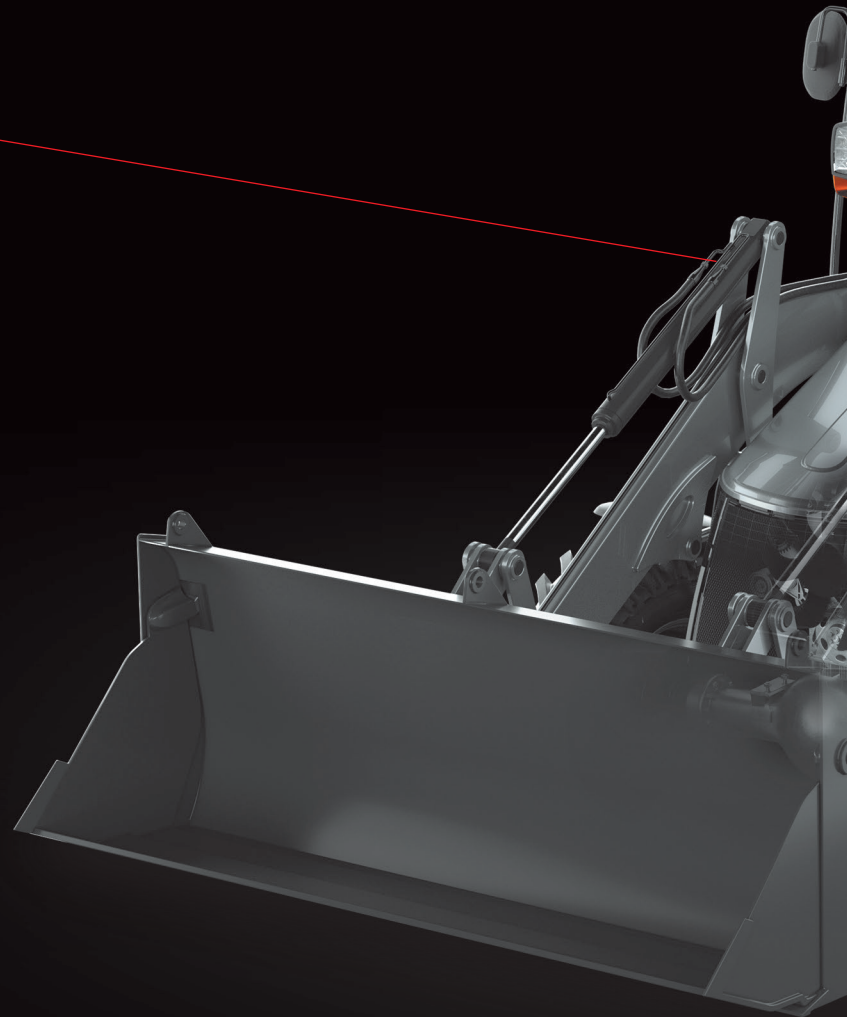

GREASE POINTS

MULTIPLEX® FS 220

Premium quality, synthetic, extreme-pressure, lithium complex grease developed for industrial and automotive equipment operating at extreme temperatures or over a wide temperature range

MULTIPLEX FS 460

Multipurpose, synthetic, extreme-pressure lithium complex grease for industrial, mining and mobile off-road equipment operating in wet conditions and extreme temperatures or over a wide temperature range

OMNIGUARD® FS XD5

Premium, synthetic, extreme-pressure calcium sulfonate grease with 5% moly. Excellent resistance to water washout, rust and corrosion

OMNIGUARD 220

Multipurpose, extreme-pressure, corrosion-preventive calcium sulfonate grease for use in equipment operating in wet or corrosive environments

OMNIGUARD XD5

Premium, extreme-pressure, calcium sulfonate grease with 5% moly for use in off-road equipment manufactured by Caterpillar, Terex, Komatsu Dresser, Le Tourneau, P&H and others

DYNALIFE® 220

Multipurpose, extreme-pressure lithium grease used in a wide variety of industrial and automotive applications where operating temperatures and loads are moderate

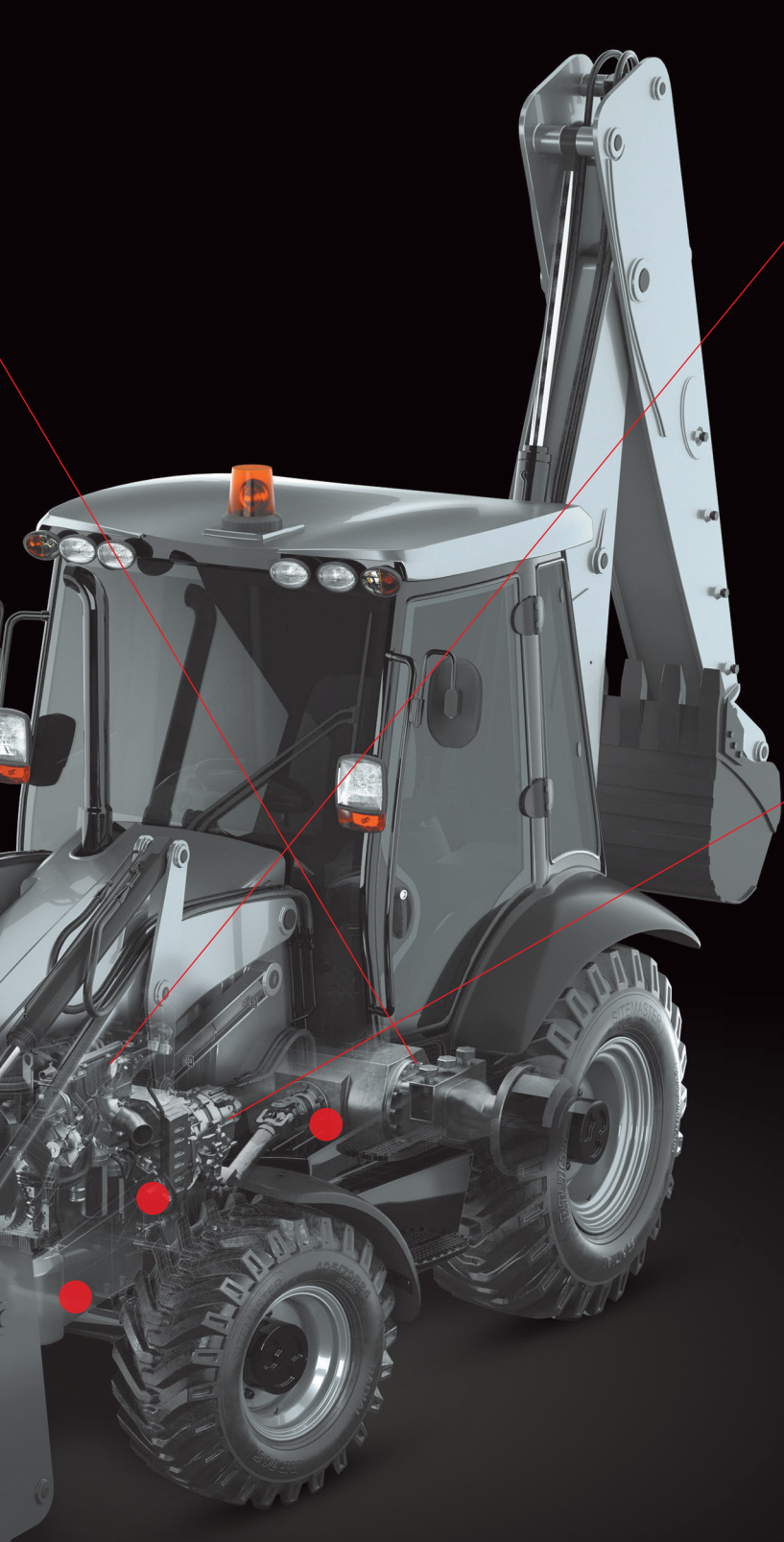

ENGINE CRANKCASE

GUARDOL ECT® 15W-40 WITH LIQUID TITANIUM® PROTECTION ADDITIVE

API CK-4 synthetic blend diesel engine oil with exclusive wear protection

FLEET SUPREME EC® 15W-40

API CK-4 diesel engine oil for low-emission engines

POWER-D® 15W-40

API CI-4 PLUS universal engine oil

TRANSMISSION

POWERDRIVE SYNTHETIC ALL-SEASON TO-4 FLUID

Premium, synthetic multifunctional fluid for transmissions, final drives and hydraulic systems where Caterpillar TO-4 requirements are specified. Ideal for extreme cold-weather applications as well as year-round service in most climates

POWERDRIVE FLUID 30

High-performance multifunctional fluid for transmissions, final drives and hydraulic systems where Caterpillar TO-4 requirements are specified

MULTIPLEX 220

Multipurpose, extreme-pressure lithium complex grease for operations at moderate to high temperatures

MULTIPLEX 600

Multipurpose, extreme-pressure lithium complex grease for equipment operating under heavy loads at moderate to high temperatures

MEGAPLEX® XD3

High performance, multipurpose, extreme-pressure lithium complex grease (3% molybdenum disulfide) developed to satisfy the severe lubrication requirements of construction and off-road equipment

MEGAPLEX XD5

High-performance, multipurpose, extreme-pressure lithium complex grease (5% molybdenum disulfide) for off-highway trucks and heavy equipment

MULTIPLEX 460

Premium-quality, extreme-pressure lithium complex grease for heavily loaded construction, mining and industrial equipment; also used as a chassis grease

CK-4 & FA-4 CERTIFIED OILS



TRITON FE
FULL SYNTHETIC
FA-4



TRITON EURO
FULL SYNTHETIC
CK-4 | MB 228.51



TRITON® ARCTIC
FULL SYNTHETIC
CK-4



TRITON ECT
FULL SYNTHETIC
CK-4



GUARDOL FE®
SYNTHETIC BLEND
FA-4



GUARDOL ECT®
SYNTHETIC BLEND
CK-4



FLEET SUPREME EC®
CONVENTIONAL
CK-4



FIREBIRD® EC
RE-REFINED
CK-4

We engineer solutions for the daily grind. Putting every product through the ringer to ensure superior performance. Like our API CK-4 and FA-4 engine oils, which endure millions of miles of testing to improve fuel efficiency and minimize emissions.

SPECIALTY LUBRICANTS FOR CONSTRUCTION

AIR TOOL/ROCK DRILL APPLICATIONS

CP OIL

Low-viscosity, corrosion-preventive oil for air tools and other pneumatic equipment lubricated through air-line lubricators

MAROK®

High-quality, adhesive extreme-pressure lubricant for air tools, rock drills, jackhammers, pavement breakers and other pneumatic equipment

ROCK DRILL OIL

Adhesive extreme-pressure lubricant for air tools, rock drills, jackhammers, pavement breakers and other pneumatic equipment

GEAR OIL OPTIONS

EXTRA DUTY GEAR OIL

Premium, extreme-pressure gear oil with "clean gear" additive technology for enclosed gear drives

GLW

Premium-quality, extreme-pressure industrial gear oil developed for the lubrication of heavily loaded enclosed gear drives operating under severe service conditions

GLW-E

Premium-quality, extreme-pressure industrial gear oil that emulsifies with water for the lubrication of heavily loaded enclosed gear drives

GEAR SHIELD®

Viscous, adhesive, residual compounded gear lubricant cut back with a volatile, non-chlorinated solvent

OPEN GEAR LUBE

Viscous, tacky, residual compounded gear lubricant cut back with a volatile, non-chlorinated solvent

HYDRAULIC SPECIALTY FLUID

POWERFLOW™ NZ HYDRAULIC OIL

Inherently biodegradable, nontoxic, zinc-free, anti-wear hydraulic oil for use in equipment operating in environmentally sensitive areas

POWERFLOW NZ HE HYDRAULIC OIL

Inherently biodegradable; high-efficiency, high VI, zinc-free anti-wear hydraulic oil; separates from water

POWERFLOW NZ HE-E HYDRAULIC OIL

High-efficiency, high VI, zinc-free anti-wear hydraulic oil; emulsifies with water

FIREBIRD AW HYDRAULIC OIL

Environmentally responsible, anti-wear hydraulic oil formulated with a blend of high-quality conventional and re-refined base stocks

SPECIALTY ARCTIC APPLICATIONS

TRITON ARCTIC DIESEL ENGINE OIL

API CK-4 full synthetic diesel engine oil for use where the low-temperature properties of an SAE 0W-40 is required

POWERDRIVE® SYNTHETIC ARCTIC TO-4 FLUID

Synthetic multigrade Caterpillar TO-4 fluid for off-highway equipment in arctic climates

SPECIALTY FINAL DRIVE

POWERDRIVE FLUID 6000

Final Drive and Axle Oil (FDAO) for Caterpillar off-highway equipment where the Caterpillar FD-1 specification is required

OTHER SPECIALTY

CIRCULATING OIL

High-quality, rust-inhibiting mineral oil for use in circulating systems subject to contamination

GEAR OILS



TRITON SYN GL
FULL SYN API GL-5



MP GEAR LUBE
API GL-5



TRITON SYNGEAR FE
FUEL-EFFICIENT
API GL-5



EXTRA DUTY GEAR OIL
PREMIUM
EXTREME-PRESSURE
INDUSTRIAL



GREASES



MEGAPLEX® XD3
NLGI #2



DYNALIFE® 220
NLGI #2



MULTIPLEX® FS 220
NLGI #2



OMNIGUARD® XD5
NLGI #2

**KEEPING THE
WORLD
RUNNING 
SMOOTHLY.**

Phillips 66[®] Lubricants offers a complete line of products for a wide variety of industries.
Check with your supplier today for more information and product availability.

For more information, call our Technical Hotline at **877.445.9198** | **PHILLIPS66LUBRICANTS.COM**
