

## T(4)-55CC-RP-HRG-T1 (ROLLER PAVER)

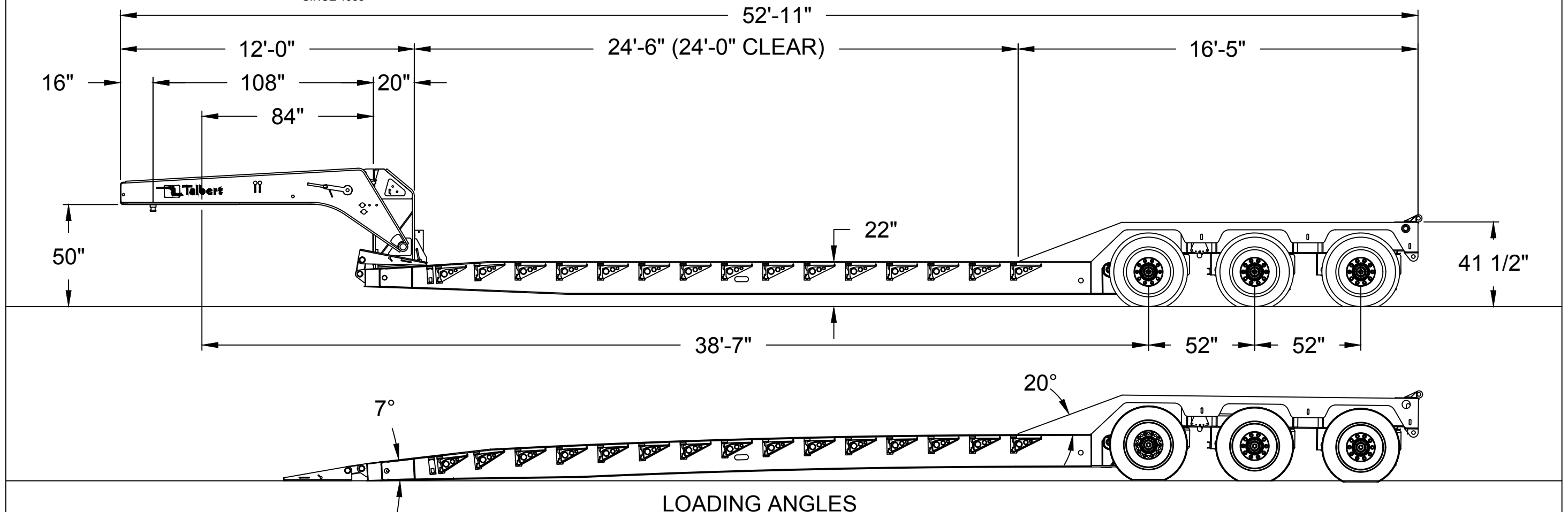

### LOADING ANGLES

- Capacity: 110,000# In A 12'-6" Two Point Rigid Load Base
- Ratchet Gooseneck Design With 5 Load Positions
- 108" Swing Radius With Alternate Kingpin Setting At 84" Swing Radius
- Hydraulically Operated Support Arm
- Aluminum Cover Plate To Protect Hydraulics
- Chain Bar In Gooseneck Base
- Wet-Line Operation (Gas Power Pack Optional)
- Four (4) Beam T-1/80K Construction
- 24'-6" (24'-0" Clear) Deck Length
- 8'-6" Width
- 22" Loaded Deck Height
- 6" Loaded Road Clearance
- 1-1/2" Apitong Flooring
- 12" Swinging/Removable Outriggers
- 20" Crossmember Spacings
- Auxiliary Crossmembers Outboard Mainbeams
- Deck Mainbeams Tapered Top And Bottom
- Chain Basket At Front
- 41" Wood Filled Front Ramps With Side To Side Adjustability
- 16-1/2" x 7" Brake System
- Hub Piloted Aluminum / Steel Disc Wheels
- Tires: 275/70R22.5 (H) 16 PR Radial Tires
- Ridewell Air Ride Suspension
- Manual Exhaust Valve; Air Lift 3rd Axle
- Automatic & Manual Height Controls
- Full Width Rear Platform, Apitong Flooring
- 20 Degree, Full Width Rear Ramp
- Connections For Future 4th Axle
- 7 Way Plug With L.E.D. Lights Opt. Package
- 18 Lash Rings
- Valspar R-Cure 800 Top Coat (Customer Color)

Various Options Available Upon Request (Note: Underlined items are optional equipment)