

# CLOSE COUPLE LOWBED SERIES

 **Talbert**<sup>®</sup>  
SINCE 1938

**35CC**



**35CC**



Stout boxed recessed cross-members yields extra deep rear bridge boom well; first cross-member recessed additionally.



Robust, four-cylinder hydraulic removable gooseneck maximizes lift capacity and load height.



Best in class lift capacity of any trailer on the market.

# 35CC

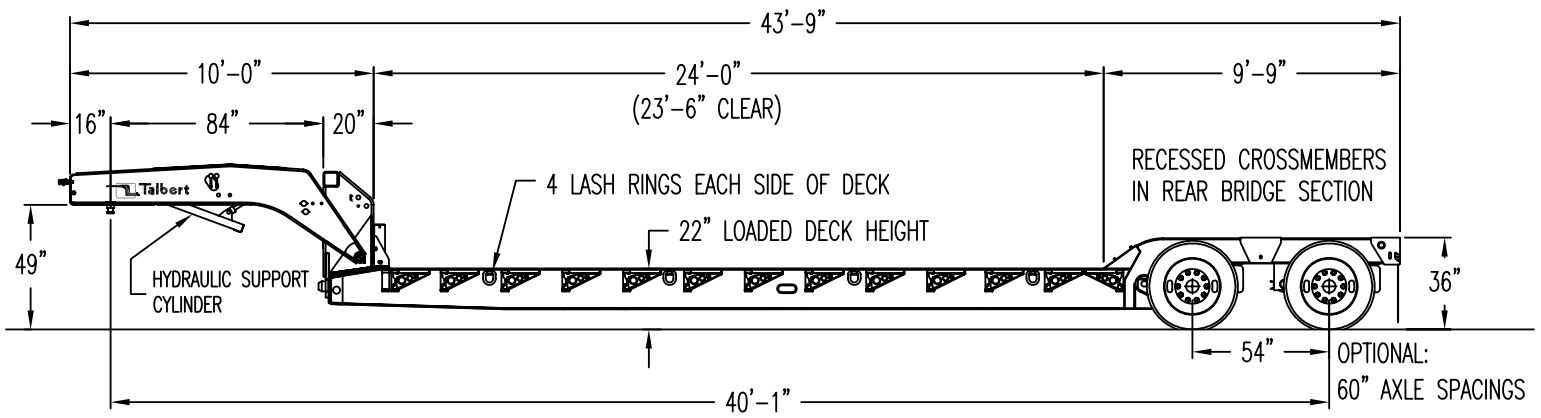

- Non-Ground Bearing Hydraulic Gooseneck Design
- 84 in. Swing Radius (Other Lengths Optional)
- Hydraulic Support Cylinder (Standard)
- Front Folding / Fixed Ramps (Optional)
- 24 ft. 0 in. Deck Length
- 12 in. Swinging / Removable Outriggers
- 8 ft. 6 in. Wide Deck
- 22 in. Loaded Deck Height
- 6 in. Loaded Road Clearance
- 1-1/2 in. Apitong Flooring
- High Strength 100,000 psi Minimum Yield Steel
- Axles: 25,000 lb. Capacity
- **RIDEWELL** Suspension: Air Ride with Automatic and Talbert +3 in. / -3 in. Manual Control
- Tires: 255/70R22.5 (H)
- Wheels: Steel Disc, Hub Piloted with Outboard Brake Drums
- Anti-Lock Brake System
- Bolsters and Half Bolster on Rear Bridge
- Adjustable Ride Height (Front and Rear)
- 36 in. Mainbeam / Bolster Height
- Boom Well In Rear Bridge
- Spring Parking Brake On One Axle
- Optional 3rd Axle
- 12 Volt LED Sealed Light System
- 70,000 lb. Capacity In 1/2 Deck Length
- Estimated Weight: 14,540 lbs.
- **Valspar** R-Cure 800 Red Or Black Paint

Various Options Available Upon Request. Specifications Subject To Change Without Notice.



Dealer:

Talbert Manufacturing Inc. \ 1628 W. State Road 114 \ Rensselaer IN 47978 \ 800-348-5232 \ Fax: 219-866-7060

sales@talbertmfg.com \ www.talbertmfg.com

0215 PUB 201C