

ROLLER PAVER SERIES



35-55 TON "RP" MODELS



35RP



55RP

RP SERIES



Newly designed, reinforced incline ramps on the 55RP feature solid, one-piece construction and integrated lockable toolbox.



50" loading ramps are wood-filled and double-hinged, providing the strength and traction needed for heavy track equipment.



Optional steel gooseneck fenders with clearance lights protect the tractor and the load from road spray.

35RP

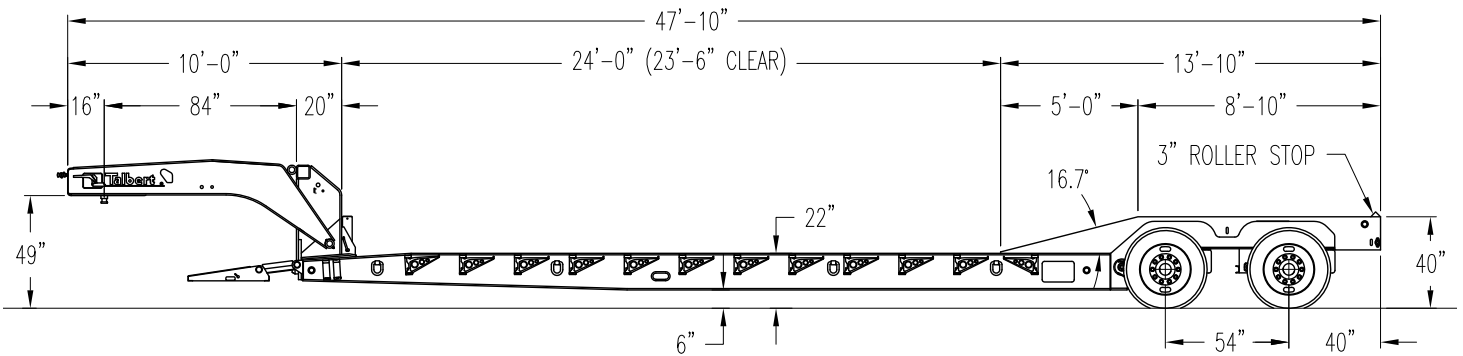

- Low-Profile HRG Gooseneck Design
- 49 in. Loaded Fifth Wheel Height
- 84 in. Swing Radius
- Standard Support Cylinder
- 4 Beam Roller Paver Deck Design
- 47 ft. 10 in. Overall Length
- 24 ft. 0 in. (23 ft. 6 in. Clear) Flat Deck
- 22 in. Loaded Deck Height
- 8 ft. 6 in. Deck Width
- 6 in. Loaded Road Clearance
- 50 in. Wood Filled Front Loading Ramp
- Rear Bridge Ramp 5 ft. 0 in. Sloped to Deck
- 1-1/2 in. Apitong Flooring
- 12 in. Swinging/Removable Outriggers
- 1/4 in. Tread Plate Over Tires
- Apitong Between Main Beams
- *RIDEWELL* Suspension: Air Ride with Automatic and Talbert +3 in. / -3 in. Manual Control
- Ride Height Control: Talbert +3/-3 Valve
- Steel Disc (Hub Piloted) Wheels
- 1 ft. 0 in. Horizontal Beavertail
- 3 in. High Roller Stop
- Lights and Wiring: Sealed Harness
- 4 Lash Rings Each Side of Deck
- Spring Brakes on 1 Axle
- 70,000 lb. Capacity in 1/2 Deck Length
- Estimated Weight: 18,910 lbs.
- *Valspar* R-Cure 800 Red or Black Paint

Various Options Available Upon Request. Specifications Subject To Change Without Notice.

55RP

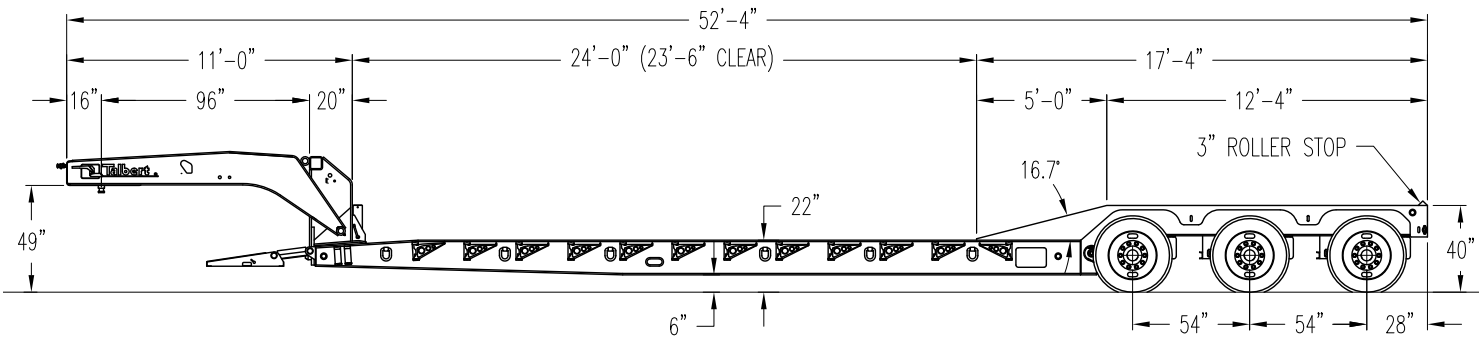

- Low-Profile HRG Gooseneck Design
- 49 in. Loaded Fifth Wheel Height
- 96 in. Swing Radius
- Standard Support Cylinder
- 4 Beam Roller Paver Deck Design
- 52 ft. 4 in. Overall Length
- 24 ft. 0 in. (23 ft. 6 in. Clear) Flat Deck
- 22 in. Loaded Deck Height
- 8 ft. 6 in. Deck Width
- 6 in. Loaded Road Clearance
- 50 in. Wood Filled Front Loading Ramp
- Rear Bridge Ramp 5 ft. 0 in. Sloped to Deck
- 1-1/2 in. Apitong Flooring
- 12 in. Swinging/Removable Outriggers
- 1/4 in. Tread Plate over Tires
- Apitong Between Main Beams
- Suspension: Air Ride with Automatic and Talbert +3 in. / -3 in. Manual Control
- Ride Height Control: Talbert +3/-3 Valve
- Steel Disc (Hub Piloted) Wheels
- 3 in. High Roller Stop
- Lights and Wiring: Sealed Harness
- 6 Lash Rings Each Side of Deck
- Spring Brakes on 1 Axle
- 110,000 lbs. Distributed
100,000 lbs. in 16 ft.
- Estimated Weight: 22,400 lbs.
- *Valspar* R-Cure 800 Red or Black Paint

Various Options Available Upon Request. Specifications Subject To Change Without Notice.

Dealer:



Talbert Manufacturing Inc. \ 1628 W. State Road 114 \ Rensselaer IN 47978 \ 800-348-5232 \ Fax: 219-866-7060

sales@talbertmfg.com \ www.talbertmfg.com

0215 PUB 232A