

KNAPHEIDE
SINCE 1848

// KMT2/KMT3

MECHANICS TRUCKS



KNAPHEIDE MECHANICS TRUCKS

Knapheide Mechanics Trucks come equipped with standard features to help you get the job done. With secure side compartments and an oversized cargo space, you can carry everything you need.

Choose a Knapheide Mechanics Truck for the durability and functionality that stands above the rest

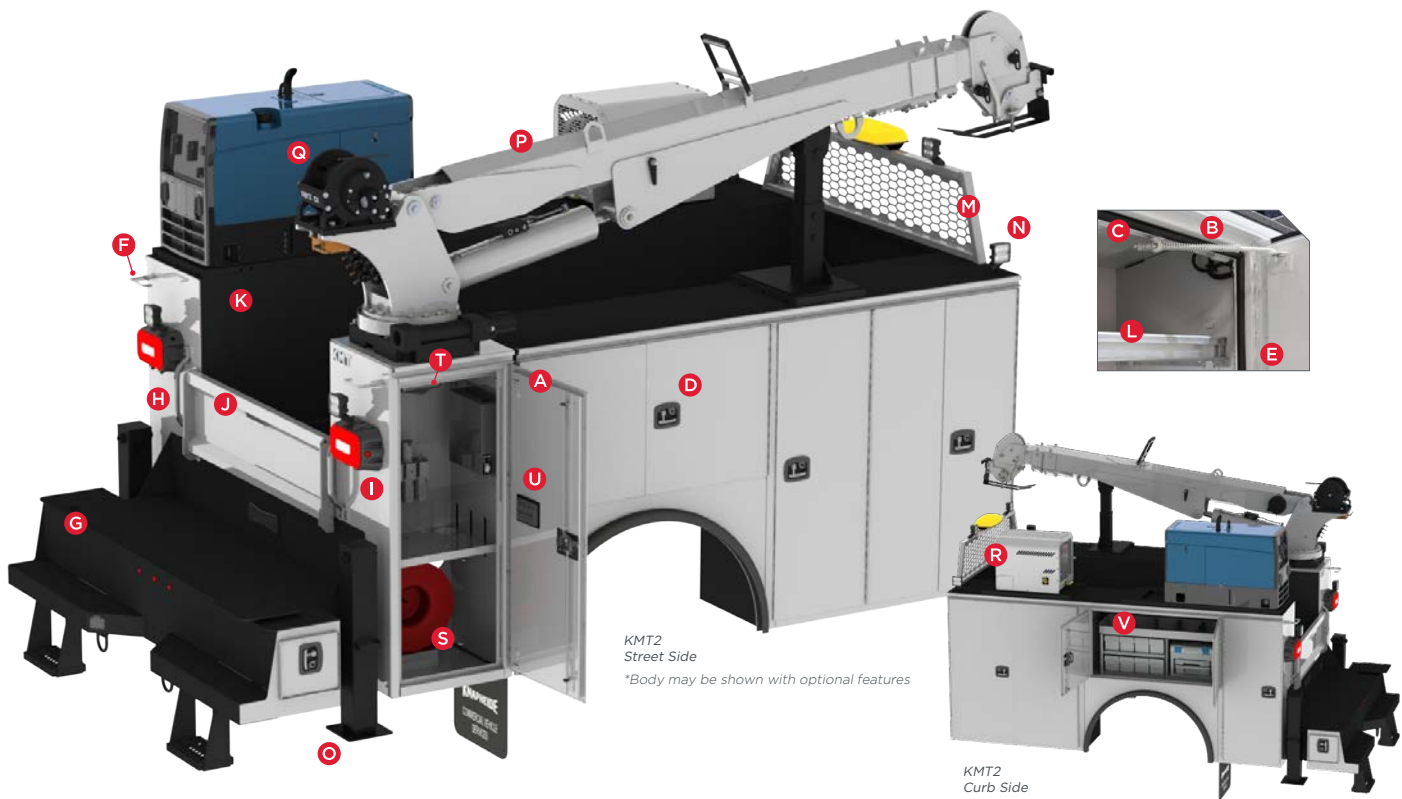

// KMT2/KMT3 MECHANICS TRUCKS

Count on the Knapheide KMT2 and KMT3 Mechanics Trucks for the most demanding lifting applications. These bodies are compatible with Class 6-8 trucks.

CRANE BODY UNDERSTRUCTURE

- Unique torq-isolator crane support system transfers lift forces into the full length torsion box subframe and outriggers, and not the side compartments
- Reinforced rear vertical curb side compartment is independent of all other side compartments, eliminating flexing and twisting of side packs

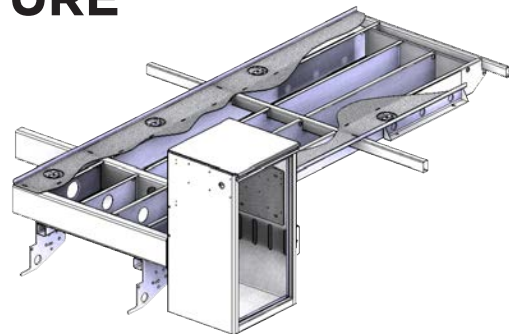

REQUEST A QUOTE

Visit knapheide.com/quote and fill out the form to receive a quote and additional product information.

STANDARD FEATURES

- A** Double paneled doors made of galvanized steel (14-gauge outer panel, 20-gauge inner panel) are reinforced with internal braces for durability
- B** Vertical compartment doors employ double-spring over-center retainer to eliminate involuntary swing
- C** Neoprene door seals protect compartments from the weather
- D** Automotive quality 3-point T-handle latches
- E** Continuous stainless steel hinges are pry-proof and corrosion-resistant
- F** Master locking system locks down all compartments on one side with one motion
- G** Knapliner work surface bumper with lockable through compartment, a vise plate, and two grip strut flex steps
- H** Heavy duty aluminum grab handles installed on both sides at rear of the body for easy cargo access
- I** Upgraded LED S/T/T and B/U, LED strobes with (8) selectable patterns and built-in reflectivity mounted to external rear light boxes made of UV-resistant ABS material
- J** 16" high double panel slam tailgate with center latch and flat space for displaying company graphics
- K** Knapliner applied to cargo floor, sides, compartment tops, bulkhead, bumper and tailgate for durability
- L** Includes 250-lb. capacity adjustable divider shelves
- M** Weld on cab protector with fully punched window for visibility
- N** (4) LED 1200 lumen work lights installed for low-light working conditions
- O** Hydraulic out-and-down curb side outrigger and hydraulic down street side outrigger for crane stability during lifting operations
- P** 66,000 ft-lb. crane with 21' hydraulic reach, provided by a two-stage hydraulic extension (KMT2)
70,000 ft-lb. crane with 30' hydraulic reach, provided by a two-stage hydraulic extension (KMT3)
- Q** Planetary winch provides a 55 ft. (KMT2)/ 60 ft. (KMT3) per minute single line speed
- R** 35 CFM rotary screw hydraulic compressor on 11' models, 60 CFM on 13' and 14' models
- S** 50'x1/2" compressor hose reel and roller fairlead through curb side vertical compartment
- T** Polyethylene formed drip pan with drain hose placed under the crane manages water intrusion through the crane pedestal
- U** Knapheide controller: Power cell, controller and 8-button switch panel located in the rear compartment. CAN bus system with continuous working load of 115 amps features built-in overload current protection for system and operator safety.
- V** Sortimo parts storage containers in horizontal compartment
- Other features not shown:*
- Extreme duty aluminum mechanic drawer sets
 - Hexagonal boom eliminates boom flex and lateral movement for ultimate stability
 - 1 - 2 gas bottle retainers
 - Multi-function radio remote control provides convenient complete control of the crane
 - 6 D-ring cargo tie downs installed in the cargo floor with a 6,000-lb. capacity
 - Floor is comprised of 3/16" tread plate
 - Compartment bottoms and end panels comprised of 12-gauge galvanized steel
 - Bodies are fully protected with Knapheide's water-based undercoat
 - Electrodeposition prime-paint system provides superior corrosion resistance

POPULAR OPTIONS



AUXILIARY LIGHTING



CARGO COVER



APU UNIT



LED COMPARTMENT LIGHTS



STEEL MECHANIC DRAWERS



ADDITIONAL MECHANIC DRAWERS



LUBE SKID



WELDER



SORTIMO



8x BUTTON KEYPAD

AVAILABLE MODELS

MODEL	GVWR MIN./RANGE	BUMPER	BODY LENGTH	COMPARTMENT HEIGHT	COMPARTMENT DEPTH	CARGO AREA WIDTH	TOPS & BACKS	REAR HITCH
KMT2-11	26,000	24" with step down	11'	60"	22"	50"	10ga high yield steel	Pintle mount plate below bumper
KMT2-13	26,000	24" with step down	13'	60"	22"	50"	10ga high yield steel	Pintle mount plate below bumper
KMT2-14	26,000	24" with step down	14'	60"	22"	50"	10ga high yield steel	Pintle mount plate below bumper
KMT3-14	33,000+	28" with step down	14'	60"	22"	50"	10ga high yield steel	Pintle mount plate below bumper



COMMITMENT TO CORROSION RESISTANCE

Corrosion won't be a concern when you buy quality Knapheide products. To give you the best corrosion protection, we utilize a state-of-the-art, custom-designed, 12-step, SST cathodic electrodeposition finishing system, called "E-Coat."

It bonds prime paint to steel by an electroplating process to give you a superior coat of primer, resulting in better corrosion protection compared to spraying methods.

This system allows us to create products with the highest level of corrosion resistance available.

NEVER SETTLE

If you are going to be a leader, it takes more than building a high-quality product. It means never being totally satisfied with that product, no matter how high quality it may be. It requires constant vigilance and a willingness to take a chance on something new. And it means exceeding expectations every time. As the industry changes, one thing never will—our commitment to making customers like you as productive and efficient as possible. We know you don't settle, and we don't either. That's why we want you never to settle for anything less than Knapheide on the back of your truck.

Knapheide. Never settle.

SIX-YEAR, LIMITED WARRANTY



NO RUST THROUGH



DOOR HINGES WILL NOT FAIL OR COME OFF BODY



LATCHES AND LOCK CYLINDERS WILL NOT FAIL TO OPERATE



SHELVES WILL NOT BEND UNDER MAX. LOAD OF 250 LBS.

Visit www.knapheide.com/warranty for more information.



The Knapheide Manufacturing Company
1848 Westphalia Strasse | Quincy, IL 62305

217-222-7131
www.knapheide.com

KNAPHEIDE
SINCE 1848