

KNAPHEIDE
SINCE 1848



FORD TRANSIT
KUV BODIES

KNAPHEIDE KUV BODIES



KUV BODIES

The Knapheide KUV is available in multiple heights and lengths for different applications. It is designed to increase productivity and efficiency through better organization of parts and equipment for specialty contractors, including plumbers, HVACR technicians, electricians, and more.

No more looking for what you need — just grab and go!



KNAPHEIDE UTILITY VAN

Working out of a Knapheide KUV keeps you organized and productive. Large perimeter bins are easy to access and keep your parts and tools separated into easy-to-manage spaces.

A spacious cargo storage area with corrugated steel floor for transporting drywall, larger tools, water heater, and oversized items.

POPULAR VOCATIONS



CONSTRUCTION

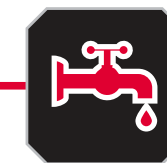

PLUMBING

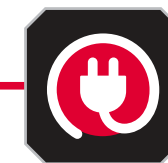

ELECTRICAL

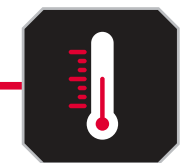

HVACR

A. DOUBLE PANELED DOORS

made of galvanized steel (14-gauge outer panel, 20-gauge inner panel) are reinforced with internal braces for durability

B. TWO CONDUIT CHUTES

to transport copper pipes, PVC, and conduit

C. AUTOMOTIVE-QUALITY, ROTARY-STYLE LATCHES

make opening and closing easy

D. ELECTRODEPOSITION PRIME-PAINT SYSTEM

provides superior corrosion resistance

E. FLAT PANEL SPACE

provides rolling billboard to promote business

F. INTEGRATED LED S/T/T AND B/U, LED STROBE OPTION*

with (8) selectable patterns and built-in reflectivity for additional safety**

*Additional wire harness required for strobe lights
**Covered under 3-year limited warranty

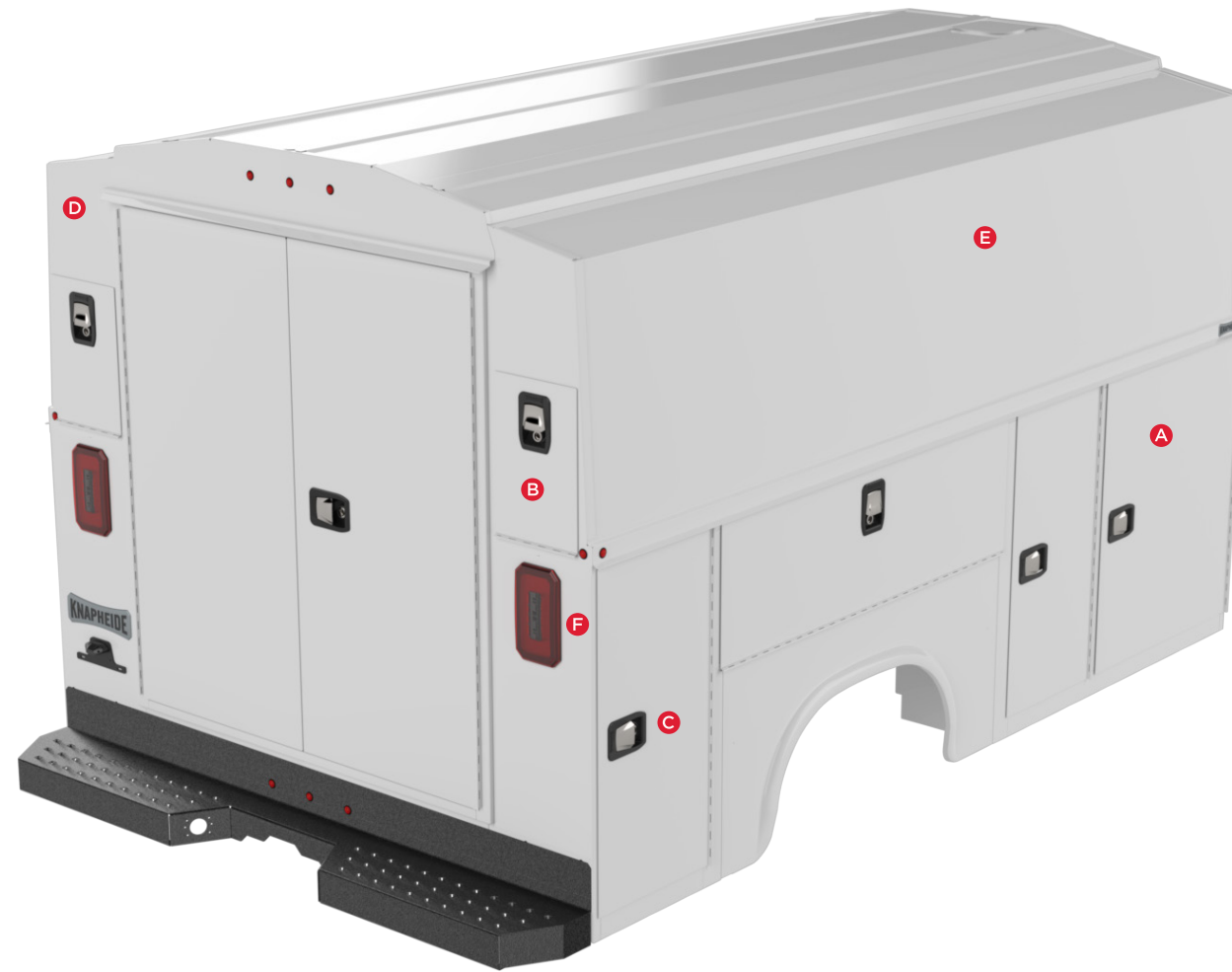

COMPARTMENT FEATURES



DOUBLE-SPRING OVER-CENTER RETAINER

on vertical compartment doors eliminate involuntary swing



NEOPRENE DOOR SEALS

protect compartments from the weather



POWER LOCKS

on rear cargo doors and side compartment doors offer enhanced operator convenience. System includes (2) key fobs.(Conduit chute doors do not have power locks.)



CONTINUOUS STAINLESS STEEL HINGES

are pry-proof and corrosion-resistant



AERODYNAMIC WIND DEFLECTOR

Mounted on body above cab
Standard on KUV129SH-FT and KUV129DH-FT models



CARGO AREA AND CONDUIT CHUTE CAPACITY

10' in 129" bodies
12' in 153" bodies

FEATURES NOT SHOWN

COMPARTMENTS CAN BE LOCKED INDEPENDENTLY
for maximum security

TWO INTERIOR LED DOME LIGHTS
in cargo area with light switch inside the cargo doors

REFINED ABS PARTITION
is equipped with a sliding cab access door and window. The door's slam latch can be locked from the cab and secured in either an open or closed position

ALUMINUM FUEL CUP

GRAB HANDLE
(rear right)

STANDARD SHELVING



STREET AND CURB SIDE FRONT VERTICAL COMPARTMENTS

Two adjustable divider shelves and dividers, with a 250-lb. capacity



STREET AND CURB SIDE FULL HEIGHT REAR VERTICAL COMPARTMENTS

One adjustable divider shelf and dividers, with a 250-lb. capacity



CURB SIDE HORIZONTAL COMPARTMENT

One adjustable divider shelf and dividers, with a 250-lb. capacity



REQUEST A QUOTE



Visit knapheide.com/quote and fill out the form to receive a quote and additional product information.

POPULAR OPTIONS



MASTER LOCKING SYSTEM



CODEABLE PADLOCK



UPPER SIDE GLASS



E-TRACK



LED COMPARTMENT LIGHTING



MECHANICS VISE BRACKET
Vise sold separately



REAR VISION CAMERA



ALUMINUM DRAWERS



SORTIMO



SPITZLIFT



SIDE ACCESS DOOR



3 BOW LADDER RACK



REAR DOOR WINDOWS



CLASS V RECEIVER HITCH



PULL OUT TRAY



SIDE MOUNT LADDER RACK



DROP-DOWN LADDER RACK
Prime Design



REQUEST A QUOTE



Visit knapheide.com/quote and fill out the form to receive a quote and additional product information.

MODEL OPTIONS

KUV BODIES

CHASSIS MODEL	CHASSIS GVWR	CA	AXLE	DRIVE	CHASSIS WEIGHT	BODY MODEL	BODY WEIGHT	PAYLOAD
T-350 Cutaway W5P 3.5L EcoBoost	9,500 lb.	82.5"	SRW	RWD	4,314 lb.	KUV129SU-FT	1,898 lb.	3,234 lb.
						KUV129SL-FT	1,884 lb.	3,248 lb.
						KUV129SH-FT	2,258 lb.	2,874 lb.
T-350 Cutaway W7P 3.5L EcoBoost	9,500 lb.	82.5"	SRW	AWD	4,544 lb.	KUV129SU-FT	1,898 lb.	3,058 lb.
						KUV129SL-FT	1,884 lb.	3,072 lb.
						KUV129SH-FT	2,258 lb.	2,698 lb.
T-350 HD Cutaway U6P 3.5L EcoBoost	11,000 lb.	82.5"	DRW	RWD	4,545 lb.	KUV129DU-FT	1,912 lb.	4,494 lb.
						KUV129DL-FT	1,902 lb.	4,449 lb.
						KUV129DH-FT	2,003 lb.	4,398 lb.
T-350 HD Cutaway U6P 3.5L EcoBoost	11,000 lb.	82.5"	DRW	AWD	4,759 lb.	KUV129DU-FT	1,912 lb.	4,329 lb.
						KUV129DL-FT	1,902 lb.	4,339 lb.
						KUV129DH-FT	2,003 lb.	4,238 lb.
T-350 HD Cutaway U6P 3.5L EcoBoost	11,000 lb.	100.2"	DRW	RWD	4,654 lb.	KUV153DU-FT	2,209 lb.	4,083 lb.
						KUV153DL-FT	2,190 lb.	4,102 lb.
						KUV153DH-FT	2,574 lb.	3,718 lb.
T-350 HD Cutaway U6P 3.5L EcoBoost	11,000 lb.	100.2"	DRW	AWD	4,759 lb.	KUV153DU-FT	2,209 lb.	4,032 lb.
						KUV153DL-FT	2,190 lb.	4,051 lb.
						KUV153DH-FT	2,574 lb.	3,667 lb.

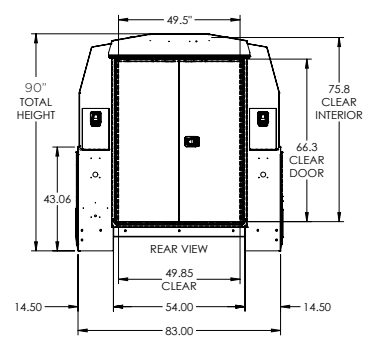
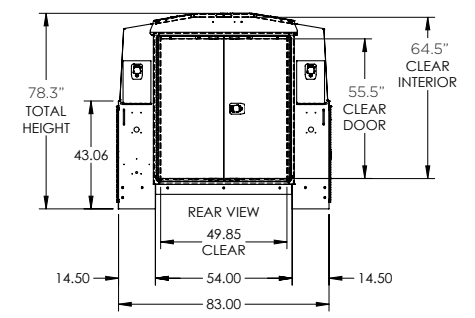
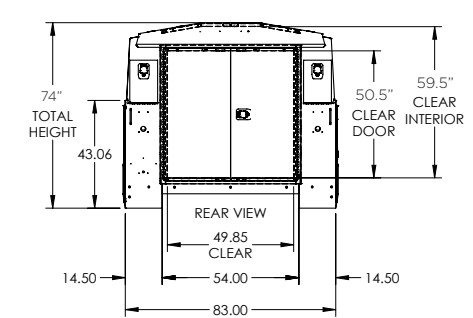
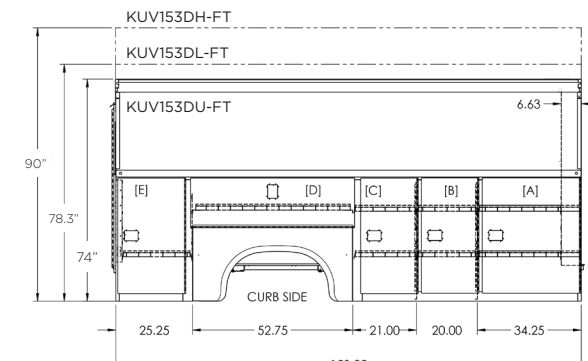
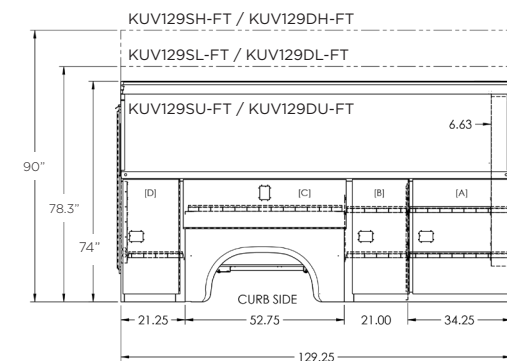

**KUV129SU-FT
KUV129DU-FT
KUV153DU-FT**

**KUV129SL-FT
KUV129DL-FT
KUV153DL-FT**

**KUV129SH-FT
KUV129DH-FT
KUV153DH-FT**

COMMITMENT TO CORROSION RESISTANCE

Corrosion won't be a concern when you buy quality Knapheide products. To give you the best corrosion protection, we utilize a state-of-the-art, custom-designed, 12-step, SST cathodic electrodeposition finishing system, called "E-Coat."

It bonds prime paint to steel by an electroplating process to give you a superior coat of primer, resulting in better corrosion protection compared to spraying methods.

This system allows us to create products with the highest level of corrosion resistance available.



FOLLOW US
LIKE US
TAG US



SIX YEAR, LIMITED TIME WARRANTY



**NO RUST
THROUGH**



**DOOR HINGES
WILL NOT FAIL OR
COME OFF BODY**



**LATCHES AND LOCK
CYLINDERS WILL NOT
FAIL TO OPERATE**



**SHELVES WILL NOT
BEND UNDER MAX.
LOAD OF 250 LBS.**

TO LEARN MORE VISIT
www.knapheide.com/warranty



NEVER SETTLE

If you are going to be a leader, it takes more than building a high-quality product. It means never being totally satisfied with that product, no matter how high quality it may be. It requires constant vigilance and a willingness to take a chance on something new. And it means exceeding expectations every time. As the industry changes, one thing never will—our commitment to making customers like you as productive and efficient as possible. We know you don't settle, and we don't either. That's why we want you never to settle for anything less than Knapheide on the back of your truck.

KNAPHEIDE. NEVER SETTLE.



The Knapheide Manufacturing Company
1848 Westphalia Strasse | Quincy, IL 62305
217-222-7131
www.knapheide.com