

**KNAPHEIDE**  
SINCE 1848



GENERAL MOTORS  
**MECHANICS TRUCKS**



# KNAPHEIDE MECHANICS TRUCKS

Knapheide Mechanics Trucks come equipped with standard features to help you get the job done. With secure side compartments and an oversized cargo space, you can carry everything you need.

Choose a Knapheide Mechanics Truck for the durability and functionality that stands above the rest.

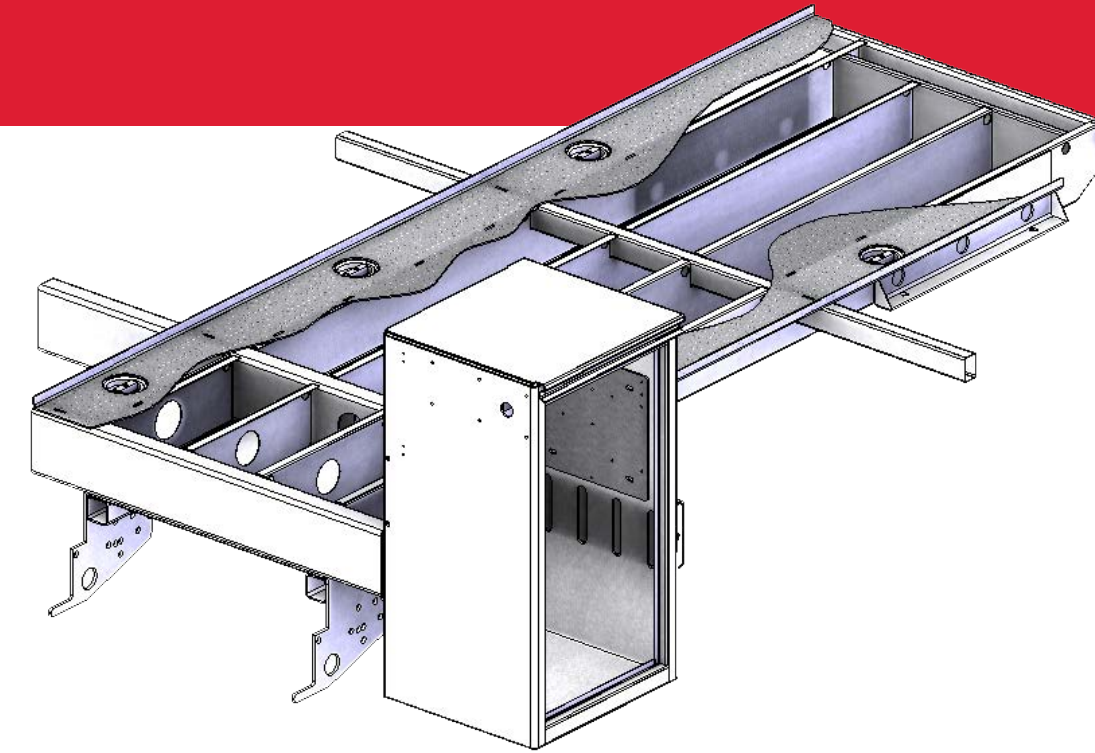

## KMT1 CRANE BODY UNDERSTRUCTURE

Unique torq-isolator crane support system transfers lift forces into the full length torsion box subframe and outriggers, and not the side compartments.

Reinforced rear vertical curb side compartment is independent of all other side compartments, eliminating flexing and twisting of side packs.

## KMT1 MODEL

The Knapheide KMT1 is purpose-built with heavy duty technicians and mechanics in mind. These bodies are built for crane load capacities of up to 7,500 lb. Knapheide KMT1 Mechanics Trucks are compatible with Class 5 trucks.

## KMS16 MODEL

The Knapheide KMS16 trucks are equipped with an electric crane. They are compatible with Class 3-5 trucks.

## POPULAR VOCATIONS



HEAVY  
CONSTRUCTION



AGRICULTURE



PREVENTATIVE  
MAINTENANCE



OIL/MINING/GAS



**A. DOUBLE PANELED DOORS**

made of galvanized steel (14-gauge outer panel, 20-gauge inner panel) are reinforced with internal braces for durability

**B. 3-POINT T-HANDLE LATCHES**

ensure your compartment doors stay closed and are individually lockable

**C. MASTER LOCKING SYSTEM**

locks down all compartments on one side with one motion

**D. KNAPLINER BUMPER**

provides work surface with lockable through compartment, a vise plate, and two grip strut flex steps

**E. HEAVY DUTY ALUMINUM GRAB HANDLES**

installed on both sides at rear of the body for easy cargo area access

**F. INTEGRATED LED S/T/T AND B/U, LED STROBES**

with (8) selectable patterns and built-in reflectivity mounted to external rear light boxes made of UV-resistant ABS material

**G. 16" HIGH DOUBLE PANEL SLAM TAILGATE**

with center latch and flat space for displaying company graphics

**H. CAB PROTECTOR**

welded-on with fully punched window for visibility

**I. (4) LED 1200 LUMEN WORK LIGHTS**

installed (2 at front, 2 at rear) for low-light working conditions

**J. HYDRAULIC OUTRIGGERS**

out-and-down curb side and hydraulic down street side for crane stability during lifting operations

**K. 44,000 FT-LB. CRANE**

with 21' hydraulic reach, provided by a two-stage hydraulic extension

**L. RECIPROCATING HYDRAULIC COMPRESSOR**

up to 40 CFM

**M. PLANETARY WINCH**

provides a 60 ft. per minute single line speed

**N. KNAPLINER**

applied to cargo area floor, sides, compartment tops, bulkhead, bumper and tailgate for durability

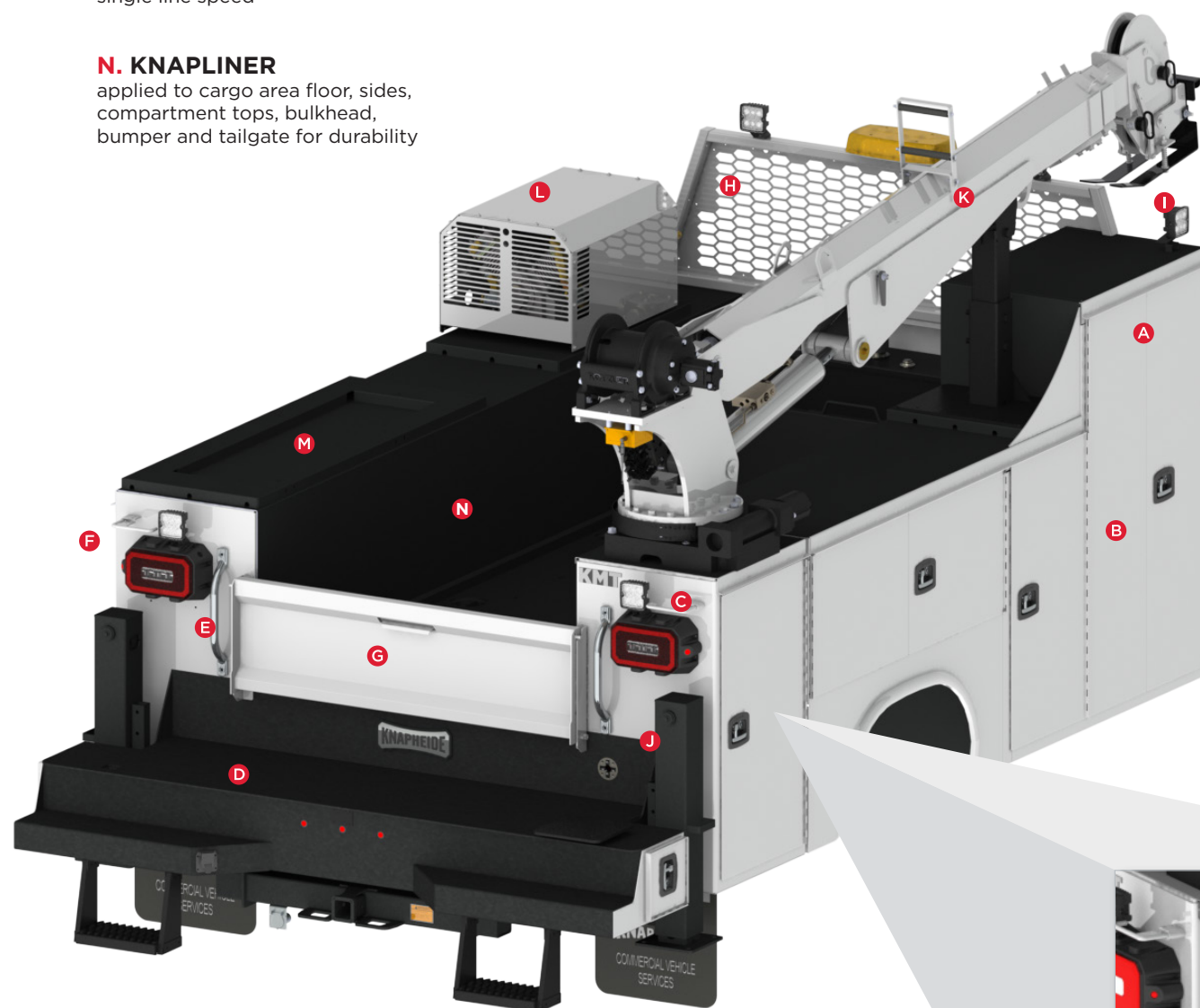

FEATURES NOT SHOWN

**SORTIMO PART STORAGE CONTAINERS**

in horizontal compartment on street side

**ALUMINUM MECHANIC 7-DRAWER SET**

Extreme duty aluminum mechanic 7-drawer set on street side

**HEXAGONAL BOOM**

eliminates boom flex and lateral movement for ultimate stability

**MULTI-FUNCTION RADIO REMOTE CONTROL**

provides convenient complete control of the crane

**KNAPHEIDE'S WATER-BASED UNDERCOAT**

Bodies are fully protected with Knapheide's water-based undercoat

**ELECTRODEPOSITION PRIME-PAINT SYSTEM**

provides superior corrosion resistance

**(6) D-RING CARGO TIE DOWNS**

each D-ring provides a 2000 lb working load capacity

**3/16" TREAD PLATE FLOOR**

provides traction for safety

**12-GAUGE GALVANNEAL STEEL**

Compartment bottoms and end panels

COMPARTMENT FEATURES



**DOUBLE-SPRING OVER-CENTER RETAINER**

on vertical compartment doors eliminate involuntary swing



**NEOPRENE DOOR SEALS**

protect compartments from the weather



**ADJUSTABLE DIVIDER SHELVES**

250-lb. capacity



**CONTINUOUS STAINLESS STEEL HINGES**

are pry-proof and corrosion-resistant

CRANE REINFORCEMENT KIT



**50' X 1/2" COMPRESSOR HOSE REEL AND ROLLER FAIRLEAD**

through curb side vertical compartment



**POLYETHYLENE FORMED DRIP PAN WITH DRAIN HOSE**

placed under the crane manages water intrusion through the crane pedestal



**KNAPHEIDE CONTROLLER**

power cell, controller and 8-button switch panel located in the rear crane compartment. CAN bus system with continuous working load of 115 amps features built-in overload current protection for system and operator system

**A. REINFORCED REAR VERTICAL CURB SIDE COMPARTMENT**

eliminates flexing and twisting of side packs

**B. DOUBLE PANELED DOORS**

made of 20-gauge galvanized steel are reinforced with internal braces for durability

**C. AUTOMOTIVE-QUALITY, ROTARY-STYLE LATCHES**

make opening and closing easy

**D. MASTER LOCKING SYSTEM**

locks down all compartments on one side with one motion

**E. KNAPLINER BUMPER**

provides versatile work space on a flat surface

**F. INTEGRATED LED S/T/T AND B/U, LED STROBES**

with (8) selectable patterns and built-in reflectivity mounted to external rear light boxes made of UV-resistant ABS material

**G. DOUBLE PANEL SLAM TAILGATE**

with center latch and flat space for displaying company graphics

**H. CAB PROTECTOR**

welded-on with fully punched window for visibility

**I. (2) LED 1200 LUMEN WORK LIGHTS**

installed for low-light working conditions

**J. HEAVY DUTY ALUMINUM GRAB HANDLES**

installed on both sides at rear of the body for easy cargo area access

**K. (1) MANUAL OUTRIGGER**

for crane stability during lifting operations

**L. 11,500 FT-LB CRANE**

at max 15' reach. (16,000 ft-lb max)

**M. PLANETARY WINCH**

provides a 15 ft. per minute single line speed

**N. KNAPLINER**

applied to cargo area floor, sides, compartment tops, bulkhead, bumper and tailgate for durability



COMPARTMENT FEATURES



**DOUBLE-SPRING OVER-CENTER RETAINER**

on vertical compartment doors eliminate involuntary swing



**NEOPRENE DOOR SEALS**

protect compartments from the weather



**ADJUSTABLE DIVIDER SHELVES**

250-lb. capacity



**CONTINUOUS STAINLESS STEEL HINGES**

are pry-proof and corrosion-resistant



**POLYETHYLENE FORMED DRIP PAN WITH DRAIN HOSE**

placed under the crane manages water intrusion through the crane pedestal

FEATURES NOT SHOWN

**SORTIMO PART STORAGE CONTAINERS**

in second horizontal compartment on street side

**ALUMINUM MECHANIC 6-DRAWER SET**

Extreme duty aluminum mechanic 7-drawer set on street side

**(6) D-RING CARGO TIE DOWNS**

each D ring provides a 2000 lb working load capacity

**KNAPHEIDE'S WATER-BASED UNDERCOAT**

Bodies are fully protected with Knapheide's water-based undercoat

**ELECTRODEPOSITION PRIME-PAINT SYSTEM**

provides superior corrosion resistance

**TORSION BOX SUBFRAME**

Full-length

**1/18" TREAD PLATE FLOOR**

provides traction for safety

**14-GAUGE GALVANNEAL STEEL**

Compartment bottoms, floors and end panels

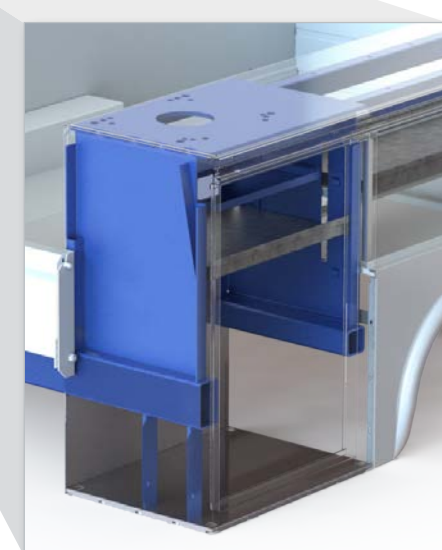

CRANE REINFORCEMENT KIT

**THE CRANE REINFORCEMENT KIT**

allows you to incorporate a crane up to 4,000 lb. capacity (16,000 ft-lb. max.) onto the rear curb side corner of your body





**REQUEST A QUOTE**

Visit [knapheide.com/quote](https://knapheide.com/quote) and fill out the form to receive a quote and additional product information.

POPULAR OPTIONS

MODEL OPTIONS



**AUXILIARY LIGHTING**



**WELDER**



**LED COMPARTMENT LIGHTS**



**CARGO COVER**



**4x BUTTON KEYPAD**



**STEEL MECHANIC DRAWERS**



**APU UNIT**



**ADDITIONAL MECHANIC DRAWERS**



**LUBE SKID**

**KMT1**

MODEL	GVWR MIN./RANGE	BUMPER	BODY LENGTH	COMPARTMENT HEIGHT	COMPARTMENT DEPTH	CARGO AREA WIDTH	TOPS AND BACKS	REAR HITCH
KMT1-11	19,500 - 22,500	24" with step down	11'	44", 60" raised front	22"	50"	1/8" smooth steel	2.5" receiver tube below bumper

**KMS16**

MODEL	GVWR MIN./RANGE	MAXIMUM CRANE	BUMPER	BODY LENGTH	COMPARTMENT HEIGHT	COMPARTMENT DEPTH	CARGO AREA WIDTH	REAR HITCH
KMS16-9	13,200-22,500	16,000 ft.-lb.	18" with outrigger tube	9'	40", 60" raised front option	20"	54"	2.5" receiver tube below bumper
KMS16-11	13,200-22,500	16,000 ft.-lb.	18" with outrigger tube	11'	40", 60" raised front option	20"	54"	2.5" receiver tube below bumper



# COMMITMENT TO CORROSION RESISTANCE

Corrosion won't be a concern when you buy quality Knapheide products. To give you the best corrosion protection, we utilize a state-of-the-art, custom-designed, 12-step, SST cathodic electrodeposition finishing system, called "E-Coat."

It bonds prime paint to steel by an electroplating process to give you a superior coat of primer, resulting in better corrosion protection compared to spraying methods.

This system allows us to create products with the highest level of corrosion resistance available.



FOLLOW US  
LIKE US  
TAG US



## SIX YEAR, LIMITED TIME WARRANTY



**NO RUST  
THROUGH**



**DOOR HINGES  
WILL NOT FAIL OR  
COME OFF BODY**



**LATCHES AND LOCK  
CYLINDERS WILL NOT  
FAIL TO OPERATE**



**SHELVES WILL NOT  
BEND UNDER MAX.  
LOAD OF 250 LBS.**

TO LEARN MORE VISIT  
[www.knapheide.com/warranty](http://www.knapheide.com/warranty)



## NEVER SETTLE

If you are going to be a leader, it takes more than building a high-quality product. It means never being totally satisfied with that product, no matter how high quality it may be. It requires constant vigilance and a willingness to take a chance on something new. And it means exceeding expectations every time. As the industry changes, one thing never will—our commitment to making customers like you as productive and efficient as possible. We know you don't settle, and we don't either. That's why we want you never to settle for anything less than Knapheide on the back of your truck.

**KNAPHEIDE. NEVER SETTLE.**



The Knapheide Manufacturing Company  
1848 Westphalia Strasse | Quincy, IL 62305

**217-222-7131**

**[www.knapheide.com](http://www.knapheide.com)**